

DANIELS FOOD EQUIPMENT

MG 180 MIXER GRINDER

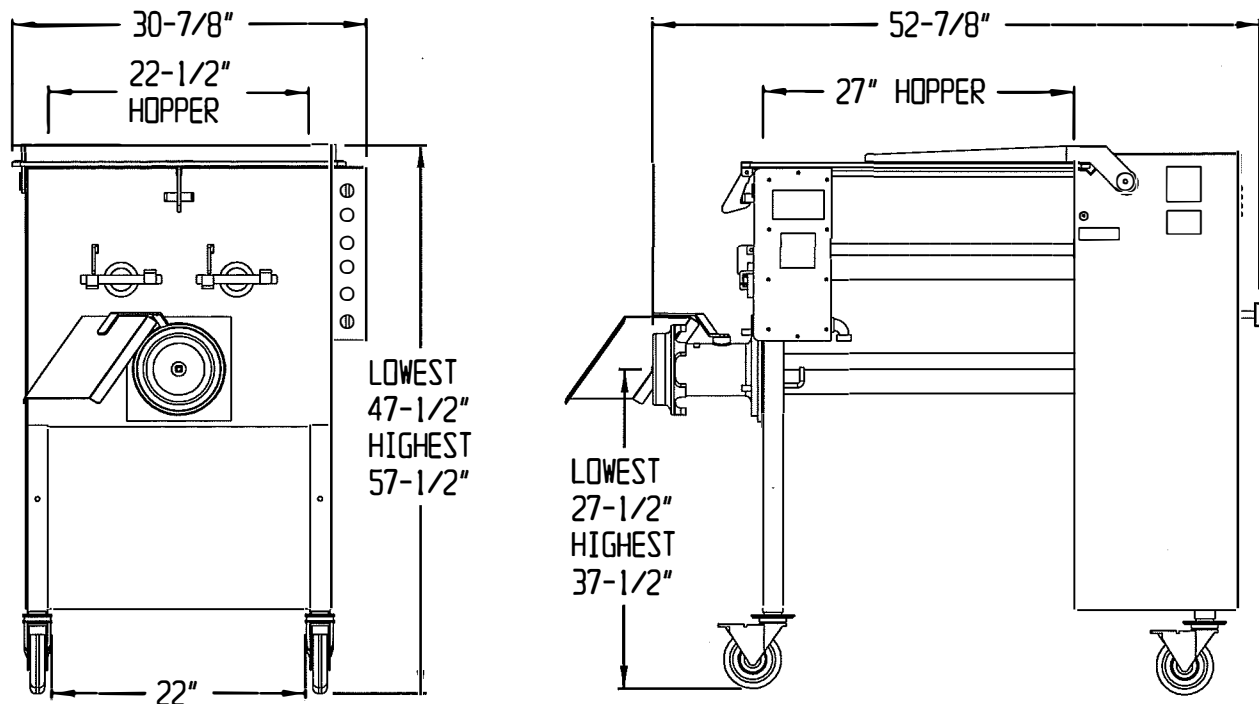

SPECIFICATIONS

- STANDARD MOTOR:** GRINDER, 208 VOLT, 15 AMP, 1725 RPM, 60 Hz, 5 HP, 3 PH.
MIXER, 208 VOLT, 3.6 AMP, 1725 RPM, 60 Hz, 3/4 HP, 3 PH.
- OPTIONAL MOTOR:** GRINDER; 230/460 VOLT, 13.2/6.6 AMP, 1725 RPM, 60 Hz, 3 PH.
MIXER; 230/460 VOLT, 3.0/1.5 AMP, 1725 RPM, 60 Hz, 3 PH.
GRINDER; 230/460 VOLT, 23/11.5 AMP, 1725 RPM, 60 Hz, 5 HP, 1 PH.
MIXER; 230/460 VOLT, 5.4/2.7 AMP, 1725 RPM, 60 Hz, 3/4 HP, 1 PH.
- HOPPER:** HEAVY GAUGE STAINLESS STEEL CONSTRUCTION, 200 LBS. CAPACITY, REMOVABLE PADDLES, CLEAR HOPPER COVER WITH SAFETY LOCKOUT.
- WORKING CAPACITY:** 180-LBS.
- WEIGHT:** 680 LBS. NET, 767 LBS. SHIPPING WEIGHT.
- OUTPUT:** UP TO 100 LBS. PER MINUTE WITH 3/8" PLATE.
- OPTIONS:** METAL GRATED LID, METAL LID, FOOT CONTROL.