

DANIELS FOOD EQUIPMENT

AFMG 300 MIXER GRINDER

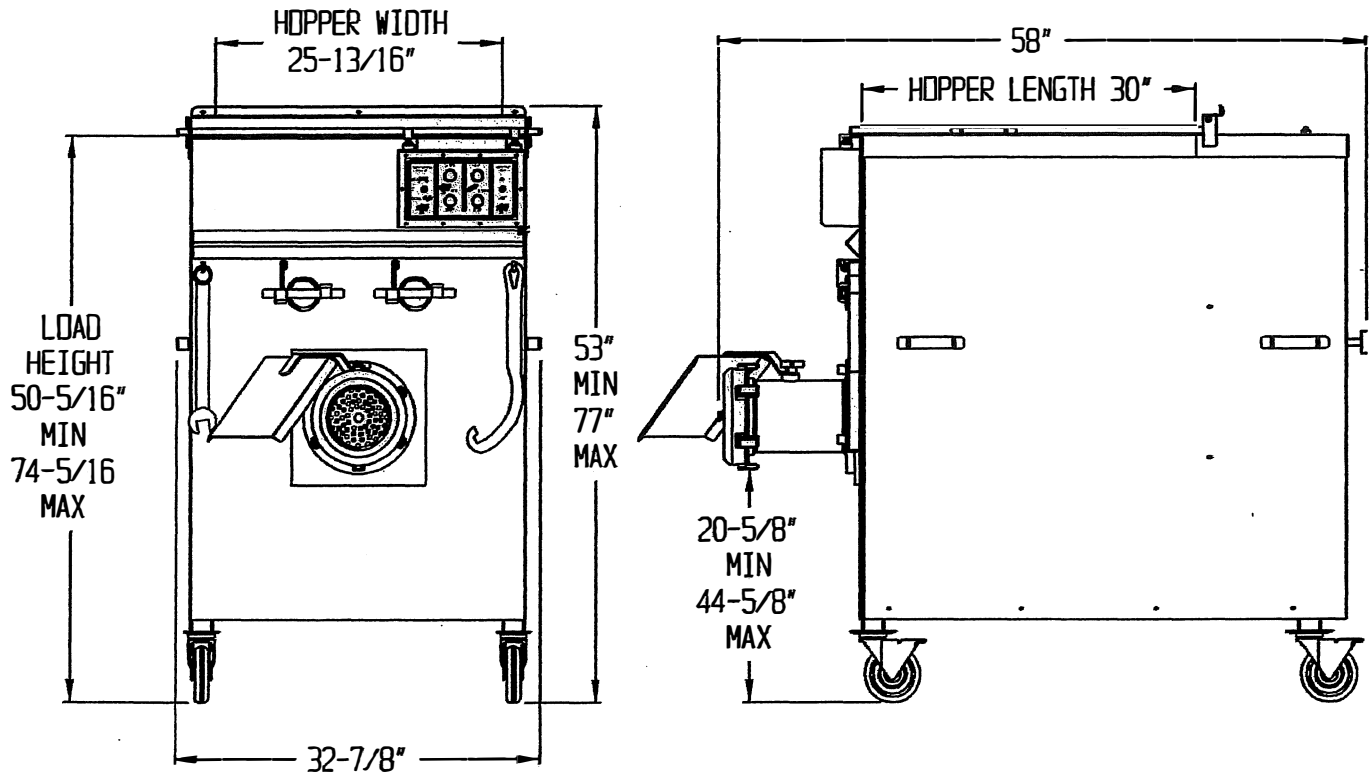

SPECIFICATIONS

- MOTOR:** GRINDER; 230/460 VOLT, 44/22 AMP, 1760 RPM, 60 Hz, 15 HP, 3 PH. OPTIONAL; 208 VOLT, 44.75 AMP, 1760 RPM, 60 Hz, 15 HP, 3 PH. MIXER; 230/460 VOLTS, 10.12/5.06 AMP 1740 RPM, 60 Hz, 3 HP, 3 PH. OPTIONAL; 208 VOLT, 10.35 AMP, 1740 RPM, 60 Hz, 3 HP, 3 PH.
- HOPPER:** HEAVY GAUGE STAINLESS STEEL CONSTRUCTION
300 LBS. CAPACITY, REMOVABLE PADDLES, STAINLESS STEEL HOPPER COVER.
- CAPACITY:** 200 - 300 LBS. PER MINUTE, DEPENDS ON PLATE HOLE SIZE AND PRODUCT CONSISTENCY.
- WEIGHT:** APPROXIMATELY 1325 LBS. SHIPPING WEIGHT 1400 LBS.